

KEISER[®] m3
M3 User and Service Manual

Table of Contents

01	M3 Features
02	M3 Computer System Features
02	Average Calculations
02	Resetting Ride Averages, Elapsed Time and Distance
03	Computer Installation
06	Mounting Computer
06	Calibrating the Computer
07	Computer Battery Replacement
07	Mounting Handlebar Assembly
08	Assembling Bike to Base Frame
09	Assembling Flywheel, Hub, and Hub Cap
09	Assembling Pedal to Crank Arm
10	Resistance Mechanism Removal
12	Resistance Mechanism Installation
15	Steps For Belt Removal
16	Steps For Belt Installation
17	Crank Arm and Axle Removal and Installation
20	Checking For Proper Operation
20	Pre-Ride Checklist
20	Test Ride
21	Preventative Maintenance Chart
22	Keiser M3 Indoor Cycle Warranty Terms
23	Keiser M3 Shift Cable Installation

About This Manual

Always follow the steps in this manual as you service the Keiser M3 Indoor Cycle. Do not skip, substitute or modify any steps or procedures herein, as doing so could result in personal injury and will void your warranty. We have put a number of precautions in this manual.

WARNING: Indicates a potentially hazardous situation which, if not avoided, could result in serious injury. By not heeding these warnings, the warranty will be void.

NOTE: Informs you about things we recommend you do or are aware of, before performing the assembly. These notes are placed in the manual to aid you during a certain procedure or to make you aware of any general mandatory actions or information.

Required Tools For M3 Servicing

#1 Phillips screwdriver	16mm or 5/8 inch open-end wrench
#2 Phillips screwdriver	Standard Screwdriver
5mm Allen wrench	Large Hammer
6mm Allen wrench	14mm Socket
Torque wrench	Crank Arm Puller (KEISER part number 505428)
15mm crowfoot	Sandpaper (medium grit or coarser)
4" extension	Heat gun or hair dryer
15mm open-end wrench	Keiser Belt Removal Kit (PN 555067)
16mm or 5/8" crowfoot	

M3 Features

- 1 Saddle
- 2 Forward/Backward Seat Adjustment T-Handle
- 3 Up/Down Seat Adjustment T-Handle
- 4 Aluminum Flywheel
- 5 Sweat Guard
- 6 Water Bottle Holder
- 7 Up/Down Handlebar Adjustment T-Handle
- 8 Handlebars
- 9 Multi-Function Computer System
- 10 Resistance Shifter
- 11 Belt Cover
- 12 Shimano™ Combo Pedals
- 13 Cycle Base
- 14 Easy Transport Wheels



M3 Computer System Features



Line 1 RPM (Cadence) - The RPM display counts the cyclist's revolutions per minute on one crank arm. RPM is known in the cycling world as Cadence and roughly is the speed at which the cyclist is pedalling. At above 140 RPM the word "STOP" will appear to indicate that the cyclist is pedalling faster than he or she needs to be.

Line 2 Power - The power output is displayed in Watts (currently generating) and Kilocalories (total value for the ride). The computer toggles back and forth between Watts (displayed for eight seconds) and Kilocalories (displayed for two seconds).

Line 3 Heart Rate - If there is no heart rate signal, a steady heart symbol and a zero will be displayed. If a participant is wearing a heart rate strap, and once the computer locks onto the signal, the heart symbol will blink and display the heart rate. Please note that the heart rate strap must be Polar™ compatible and coded.

Line 4 Pedaling or Elapsed Time - The number shown reports the total time spent cycling and will reset to zero after 60 seconds of inactivity or if the computer is reset using the gear lever.

Line 5 Odometer/Trip Distance and Gear - For the first eight seconds when the computer is first activated, the odometer will display the total distance the cycle has been ridden. This feature is for service and maintenance purposes only. After eight seconds, the odometer will display trip distance and gears from 1 - 24.

Average Calculations

To view averages: RPM (cadence), power, and heart rate at any point in the ride, stop pedalling for three seconds your averages will flash until you start pedalling again or until the computer goes to sleep after 60 seconds.

Resetting Ride Averages, Elapsed Time and Distance

To reset your averages during the ride, stop pedalling for three seconds and the averages will start to flash, while they are flashing move the gear lever from bottom to top two times quickly. This will reset your ride information back to zero.

Computer Installation

Tools needed for assembly: #1 Phillips screwdriver, #2 Phillips screwdriver



1

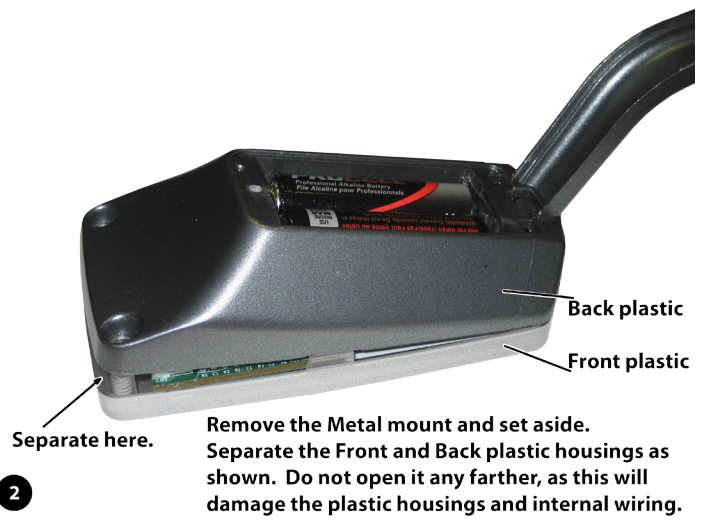

2



3



4

Circuit board must set into the corner as shown. It can be lifted out, but will not slide side to side when in its proper position.



5

LCD will break if installed in the wrong position.



6

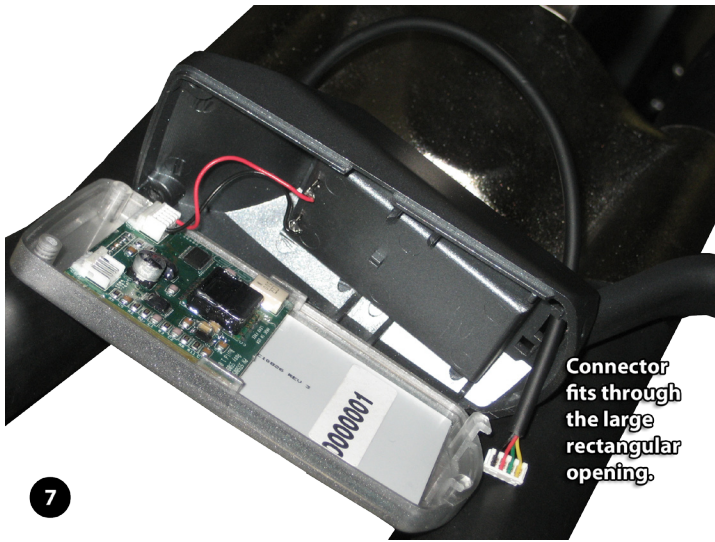

Connector fits through the large rectangular opening.

7

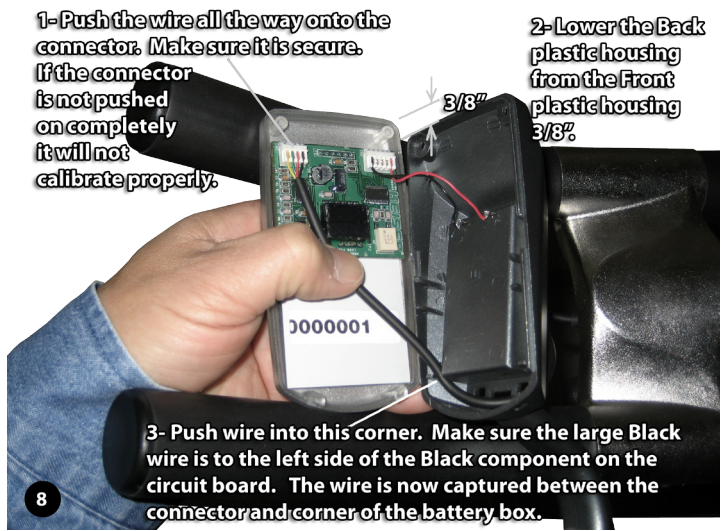

1- Push the wire all the way onto the connector. Make sure it is secure. If the connector is not pushed on completely it will not calibrate properly.

2- Lower the Back plastic housing from the Front plastic housing 3/8".

3- Push wire into this corner. Make sure the large Black wire is to the left side of the Black component on the circuit board. The wire is now captured between the connector and corner of the battery box.

8



Keep the Red and Black wires away from the Black component.

Large wire captured beside the battery box. Note: If it is not beside the battery box the wire will push against the LCD and produce a dark spot on the front of the display.

9



Reassemble the Front and Back plastic parts in reverse order of step #3. Note that the wire below the connector is running parallel to the edge of the display. If not - prebend the wire to force it in this position.

10



Reinsert the screws making them snug. Do not over tighten. (#1 Phillips screwdriver)

11



Run the wiring down the middle of the neck.

13

12. Calibrate The Computer, See Next Section

Attach the metal mount to the display. Tighten the screw so it is snug. Do not over tighten.

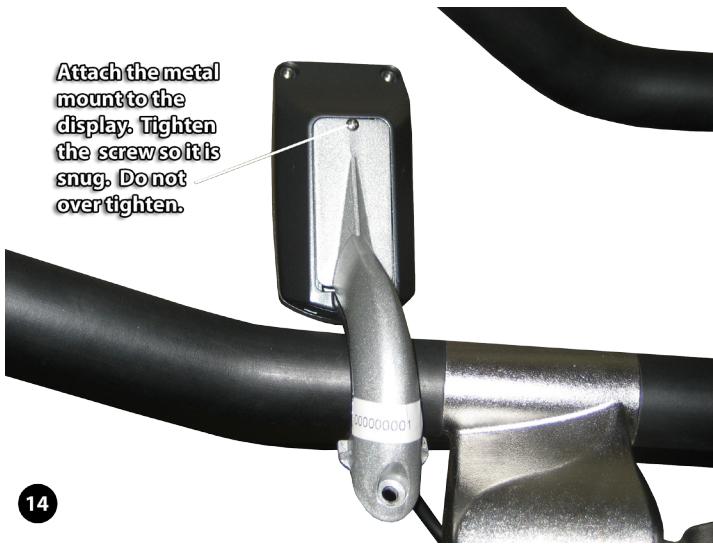

14

Remove screw to be used for mounting the display. (#2 Phillips Screwdriver) When unscrewing the hardware make sure it does not start to tighten up. If this happens: STOP! Apply a penetrating oil (like WD 40) and gently rotate the screw in and out until the screw is removed.

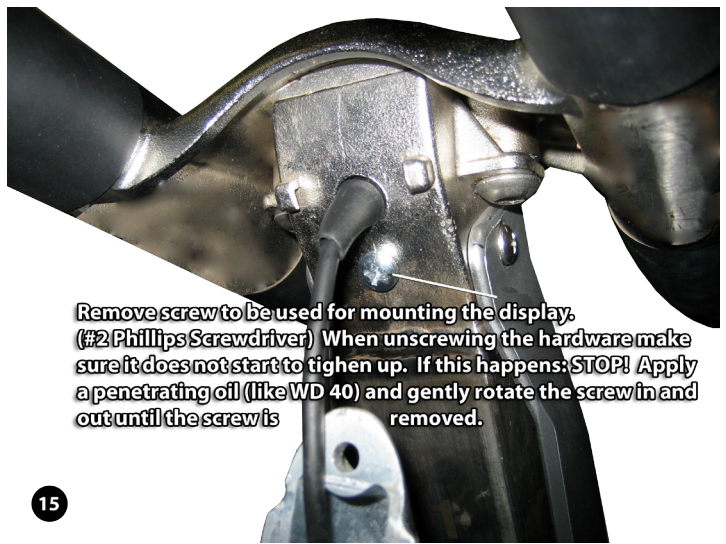

15

Hang the display down under the handlebar.

Twist the wire and display around 3 revolutions. This will put a coil in the wire. Hold the plastic and metal mount to keep them from spreading apart during twisting.

Display neck and mount.

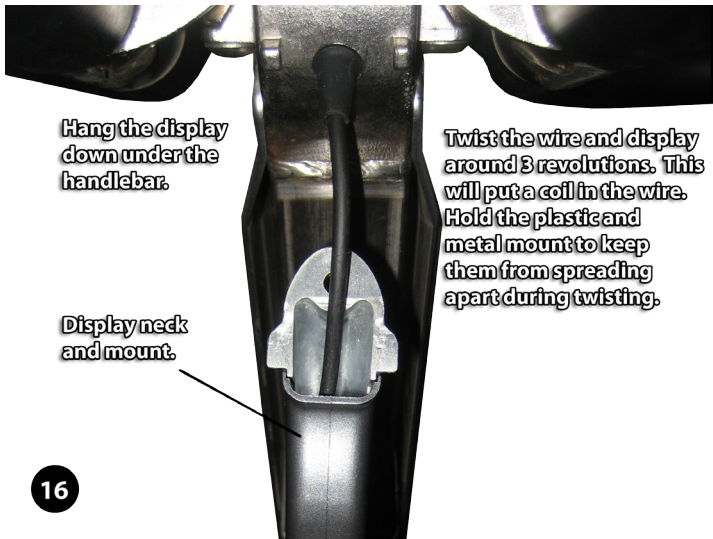

16

Twisted wire fitting into the neck of the display.



18

Rubber strain relief.

Push the twisted wire into the neck of the display as the neck covers the rubber strain relief.

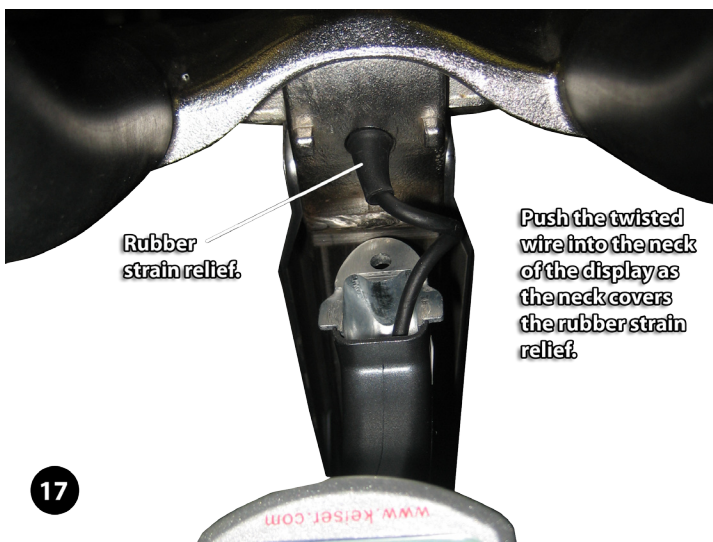

17

Hooks

Slide metal plate under the hooks as shown and reinsert the screw. Tighten until the metal mount is flush against the handlebar.

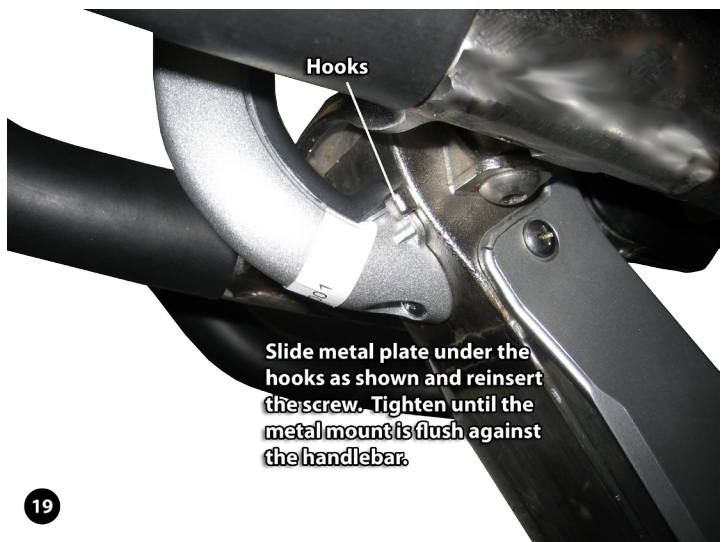

19

Mounting Computer

Step 1: Obtain the #2 Phillips screwdriver and remove the computer mounting screw from the handlebar tube.

Step 2: Coil the computer cable into the computer mount cavity.

Step 3: Slide the computer up into the two locking ears. Insert and secure the screw you removed in Step 1 using the #2 Phillips screwdriver.

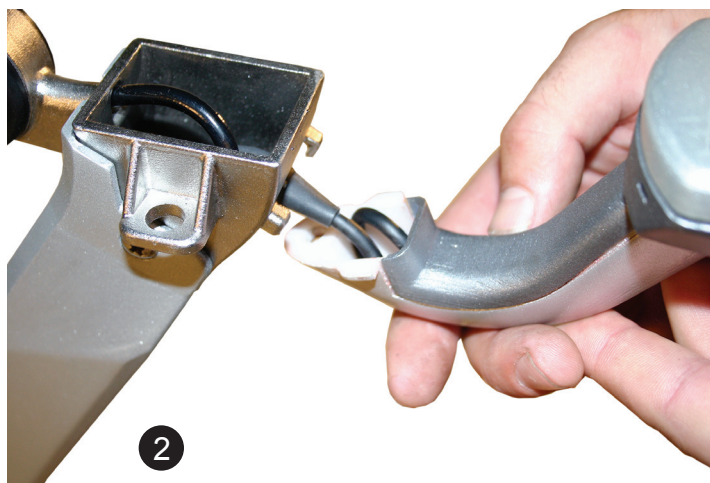

Calibrating the Computer

To calibrate the computer:

The shifter lever must be in the down position. Holding a pedal, rotate the crank arm in any direction to switch the computer on. Once the computer is on, stop rotating the crank arm. Move the shifter lever from full bottom to full top a minimum of five times. When you see the computer display a set of number fives (55:55) in the time display, the computer is calibrated.

1. Cycle display must be blank. If the display is not blank wait about 50 seconds until it is blank.
2. Activate the display by rotating the crank pedal. As soon as it is active stop the crank movement.
3. Move the shifter from full retract (lowest resistance) to full advanced (highest resistance) at least five times. These five retractions must be done within five seconds.
4. Computer will indicate it is calibrated by showing "55:55". If you do not see the "55:55" start over from step # 1.
5. Retract shifter (lowest resistance) and computer should show gear "1". Advance shifter (increase resistance) and computer should show gears changing "1" through "24".
6. Continue beyond gear "24" and "88" will flash. This is the emergency brake area, where the end of the shifter is about 1" to 1 1/4" off the top of the handlebar. If you do not see the flashing "88" start over from step # 1.



Computer Battery Replacement

To test the computer batteries rotate the crank arm until the computer “wakes up”. If the battery is low, a “LO-BA” will display in the odometer (ODO) display at the bottom of the computer. To replace the batteries unscrew the back of the computer housing and remove old AA batteries and replace with a set of two new AA batteries. If you have multiple bikes, we suggest all computer batteries be changed at the same time.



Mounting Handlebar Assembly

NOTE: If installing the M3 computer please do so before mounting the handle bars. When the computer installation is complete please return to this step.

Step 1: Obtain the handlebar assembly, 6mm Allen wrench, and the socket head cap screws (M8x1.25 X 12 SS). Observe the location of the two mounting flanges on the handlebar post. Place the handlebar assembly on the post mounts, aligning the mounting holes.

Step 2: Tilt the handlebar assembly slightly to place the socket head cap screws (M8x1.25 X 12 SS) into the mounting holes. Once each screw has been started, place the palm of one hand on the center of the handlebar pressing firmly and evenly onto the handlebar post. With the other hand tighten each screw with the Allen wrench until the head of each screw just makes contact with each hole. Now tighten each screw evenly.



Assembling Bike to Base Frame

Step 1: Carefully lower the bike onto the base frame over the base screws, with the front of the bike facing the transport wheels on the Base Frame.

Step 2: Insert one washer on each of the four base frame studs.

Step 3: Install the acorn nuts on the studs and hand tighten. Torque the acorn nuts with a 16mm or 5/8" crowfoot and torque wrench to 45 Nm (35 ft-lbs) using a 16mm, or 5/8 inch open-end wrench to hold in position.

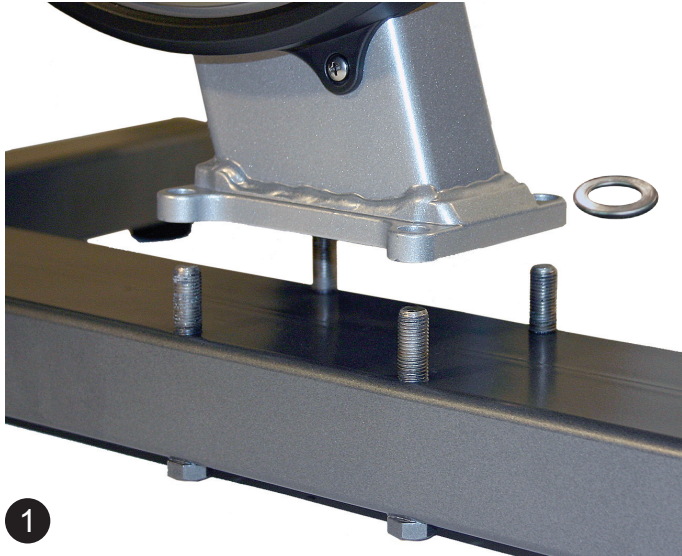

Assembling Pedal to Crank Arm

Step 1: Unwrap the pedal set and Loctite 242, obtain the Torque wrench, 15mm crowfoot, 4" extension, and 15mm open-end wrench.

Step 2: With a clean cloth, wipe the threaded area of the pedals. Apply Loctite 242 to the pedal threads. Install the pedals into the crank arms, use the 15mm open-end wrench to tighten. Finish with the torque wrench, 15mm crowfoot, and 4" extension. Torque pedals to 45 Nm (35 ft-lbs).

NOTE: Left pedal is LH threads and right pedal is RH threads.

WARNING! Failing to install the pedals with Loctite 242, or crossing the threads will damage them, and could result in serious injury to the user.



Assembling Flywheel, Hub, and Hub Cap

Step 1: Before starting the assembly of the flywheel, hub, and hub cap, make sure that the shifter lever is in the downward position.

NOTE: Not following this step may scratch the flywheel.

Step 2: Remove the plastic wrapping from around the axle, hub, and hub cap. Remove the hub cap. Obtain the 5 socket head cap screws (M6x1 X 20 SS) and 5mm Allen wrench. Remove the flywheel from its foam envelope.

NOTE: Use the foam envelope to handle the flywheel during assembly.

Step 3: Carefully slide the flywheel between the two magnets and onto the hub at the same time. Make sure that the flywheel is flush against the hub and align the screw holes.

Step 4: Holding the flywheel in position with one hand, install the hubcap and align the screw holes. Install the socket head cap screws (M6x1 X 20 SS). Using the 5mm Allen wrench, tighten the screws in a star pattern until snug.

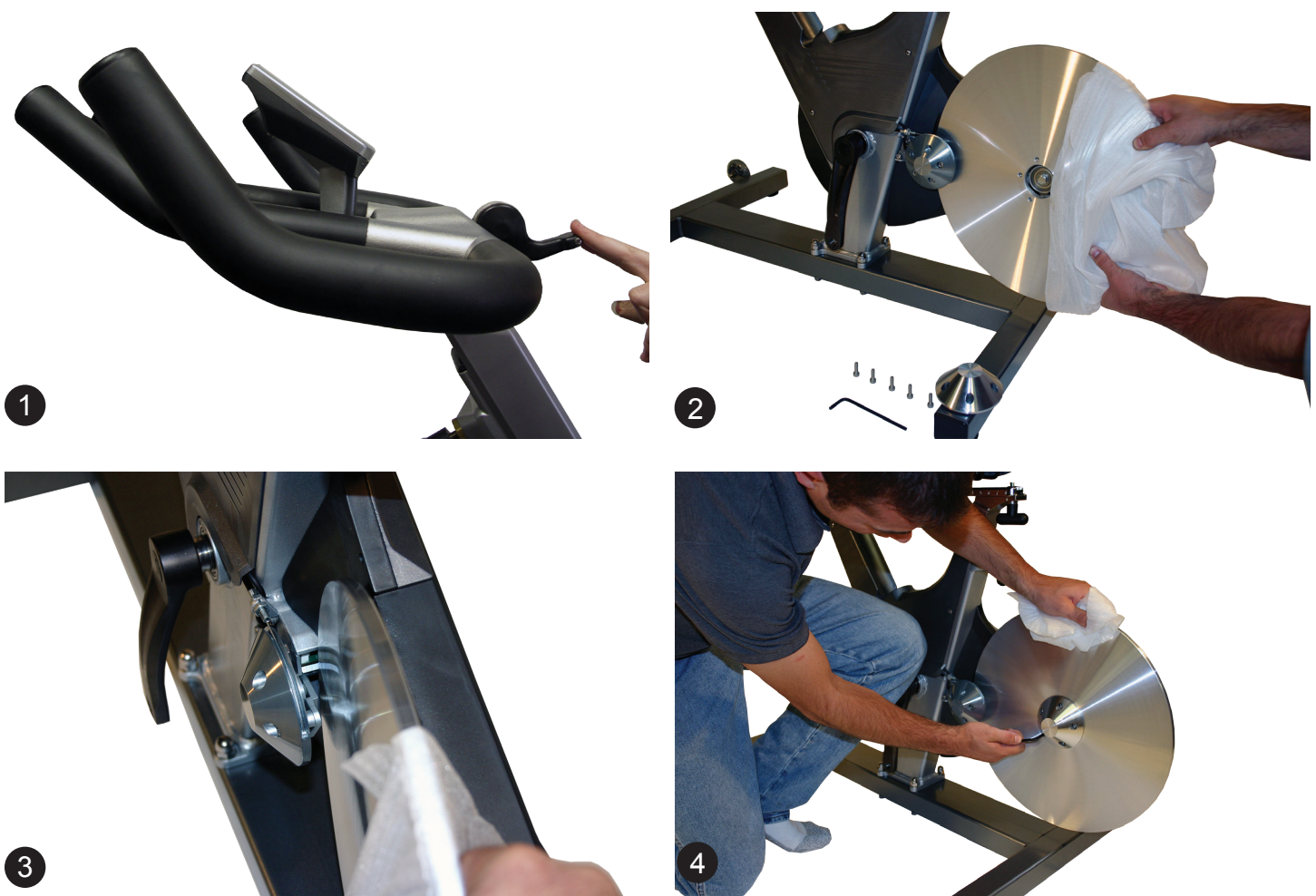

Resistance Mechanism Removal

Tools Required:
 -5 mm hex-head wrench
 -#1 phillips head screwdriver

Supplies Required:
 -Lite bearing grease
 -Loctite 242 thread locker

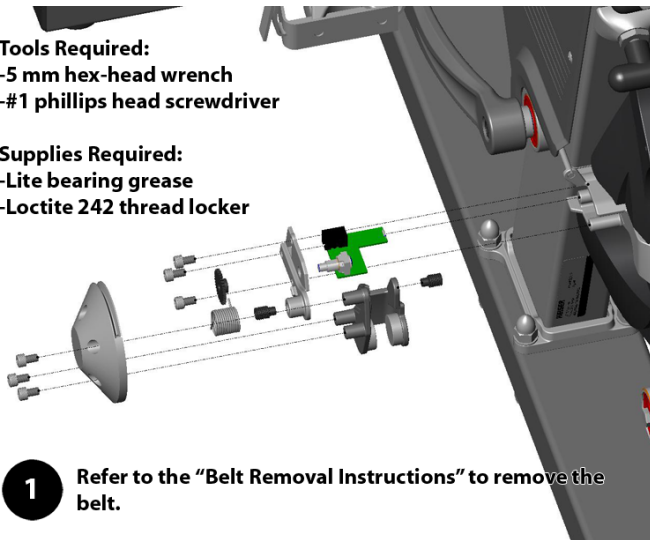

1 Refer to the "Belt Removal Instructions" to remove the belt.

Remove the flywheel:
 1. Set the shifter lever to the lowest position.
 2. Use the 5mm hex-head wrench and remove the 5 flywheel screws.
 3. Remove the hub cap.
 4. Carefully remove the flywheel from the hub.



2

Identify the resistance mechanism and related parts. With the flywheel removed it is easy to see the position of all of the components. Bikes without computers will not have a position gear or circuit board.

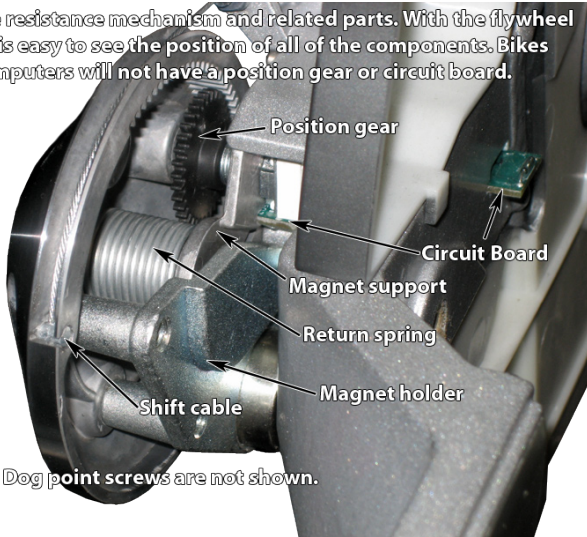

3 The Dog point screws are not shown.

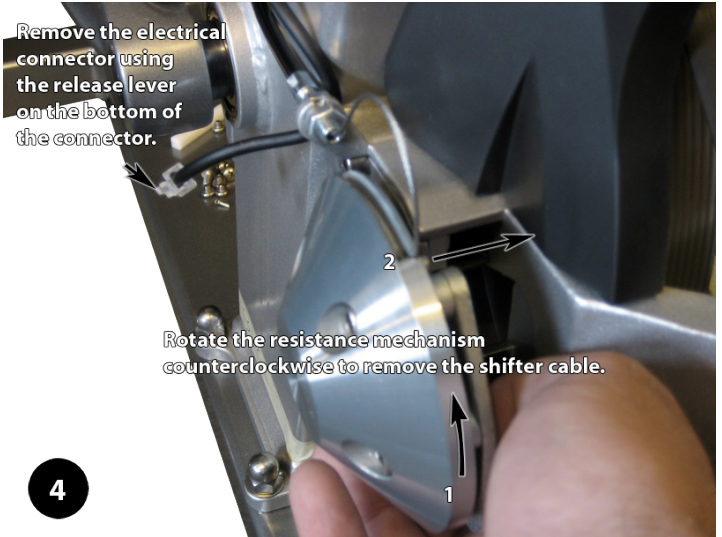

Remove the electrical connector using the release lever on the bottom of the connector.

Rotate the resistance mechanism counterclockwise to remove the shifter cable.

4

Holding the resistance mechanism, use the 5mm hex-head wrench and remove the three screws from the magnet cover. Take caution when removing the last screw because the mechanism is spring loaded.



5 After the magnet cover has been removed, remove the return spring.

The gear is pressed onto the shaft. To remove the gear use your fingers and pull straight off of the shaft.



6

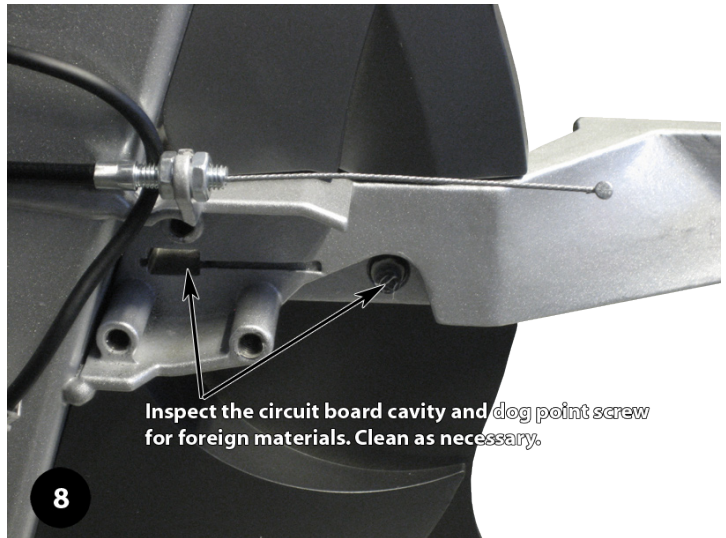
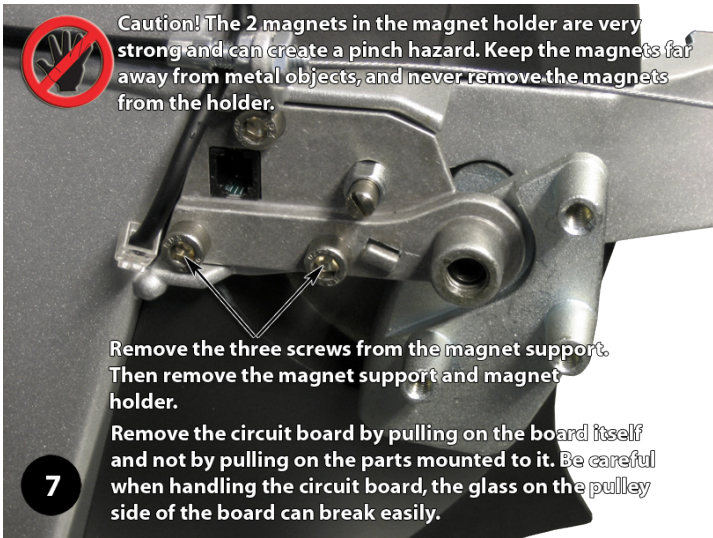

Inspect the magnet holder for foreign material on the magnet surfaces and grease on the pivot points. If necessary apply a lite bearing grease to the pivot points.

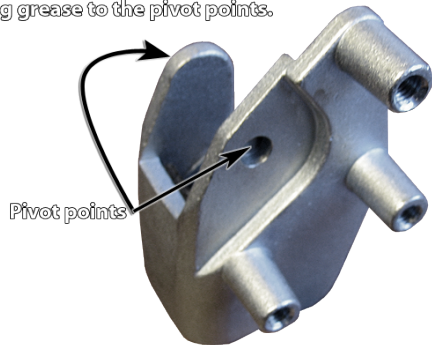

If replacing any of the parts shown below you will receive a kit that includes the magnet support, gear, circuit board, and dog point screw as shown in this picture. For proper operation carefully follow the notes below.

Do not grease the dog point screw prior to assembly, this will ensure the Loctite on the thread is not contaminated when installed.

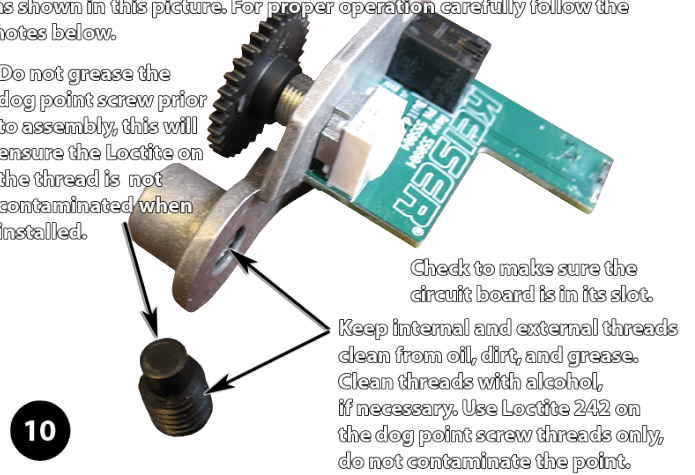

Resistance Mechanism Installation

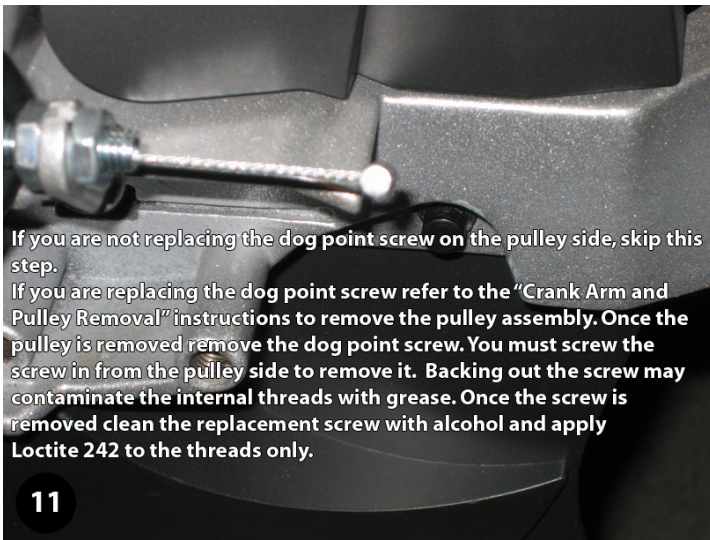

Press the gear back onto the shaft using both thumbs and forefingers, be sure to place your thumbs on the gear and fingers on the back side of the potentiometer. If you find this is too difficult, you may need to use a large set of pliers as shown. Be sure to position the pliers onto the gear and potentiometer as shown, with one jaw on the gear face and the other jaw on the back side of the potentiometer. Do not press the gear into place using the circuit board.

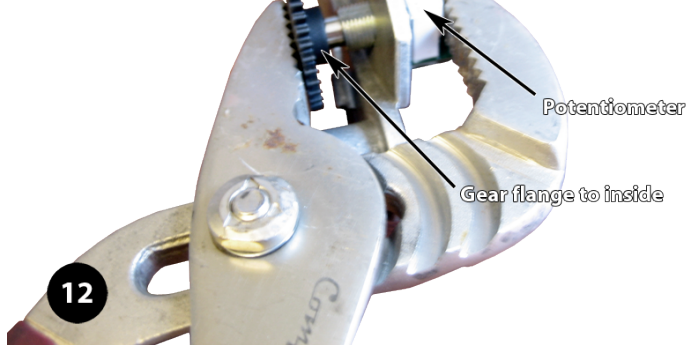

Use a piece of 8.5 inch by 11 inch computer paper, and fold as shown:

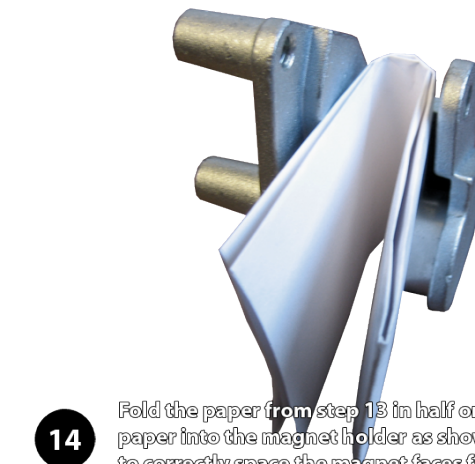
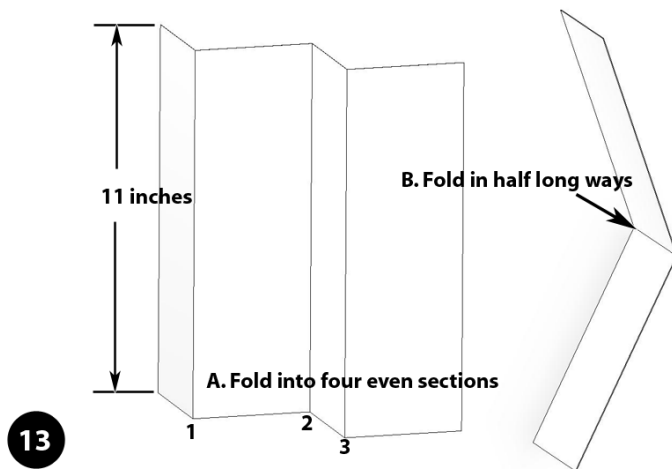

Fold the paper from step 13 in half one last time. Place the paper into the magnet holder as shown. This will be used to correctly space the magnet faces from the flywheel.

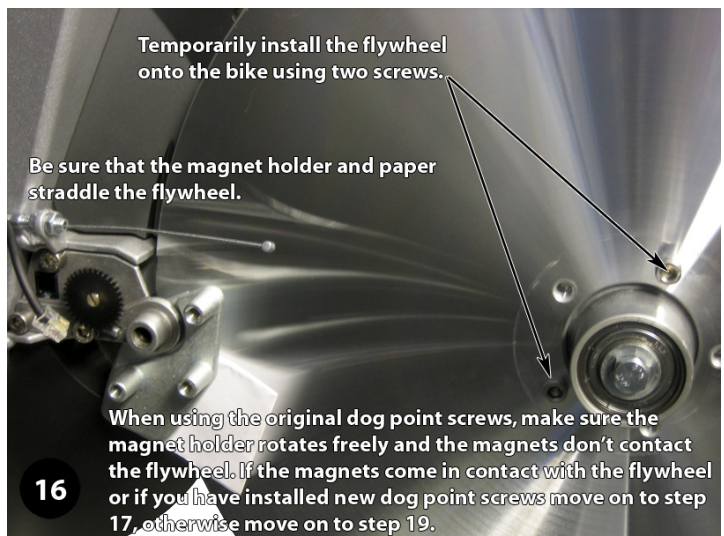
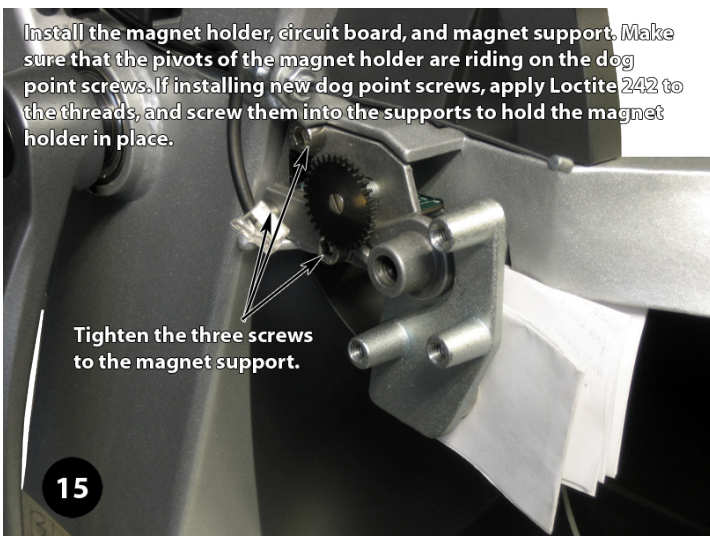

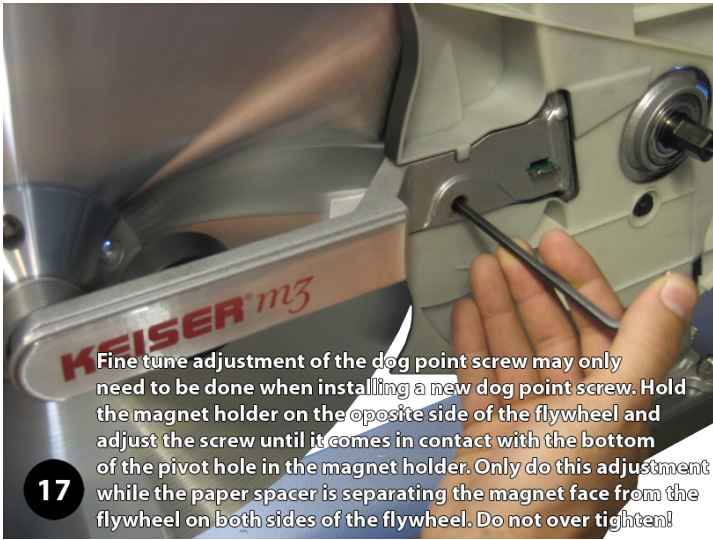

17 Fine tune adjustment of the dog point screw may only need to be done when installing a new dog point screw. Hold the magnet holder on the opposite side of the flywheel and adjust the screw until it comes in contact with the bottom of the pivot hole in the magnet holder. Only do this adjustment while the paper spacer is separating the magnet face from the flywheel on both sides of the flywheel. Do not over tighten!

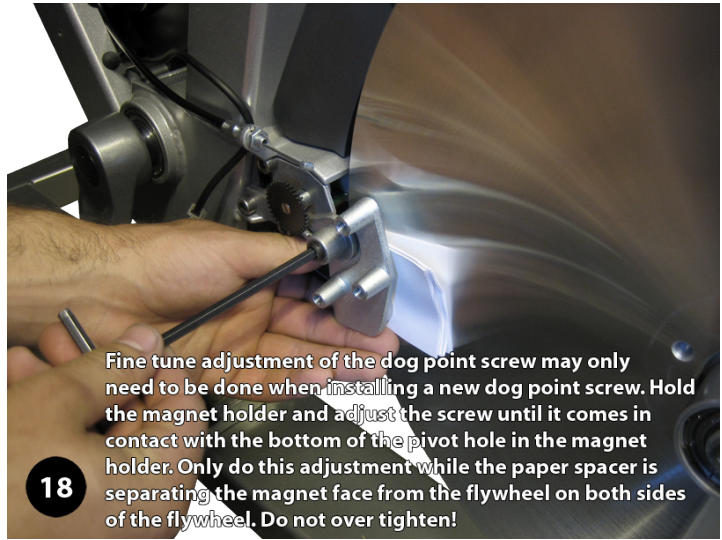

18 Fine tune adjustment of the dog point screw may only need to be done when installing a new dog point screw. Hold the magnet holder and adjust the screw until it comes in contact with the bottom of the pivot hole in the magnet holder. Only do this adjustment while the paper spacer is separating the magnet face from the flywheel on both sides of the flywheel. Do not over tighten!

Remove the paper spacer from the magnet holder. Looking down over the top of the flywheel check the magnet to flywheel spacing and make sure that there is equal spacing on both sides. If further adjustment is required do so by adjusting the dog point screws alternately. Be sure to make all of your adjustments prior to the Loctite setting up.

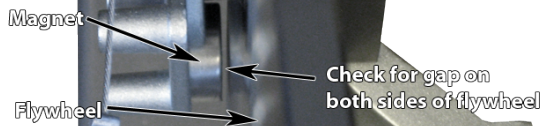

As a final check, make sure the magnet holder rotates freely, but has no side to side movement, then spin the flywheel slowly to ensure clearance.

19

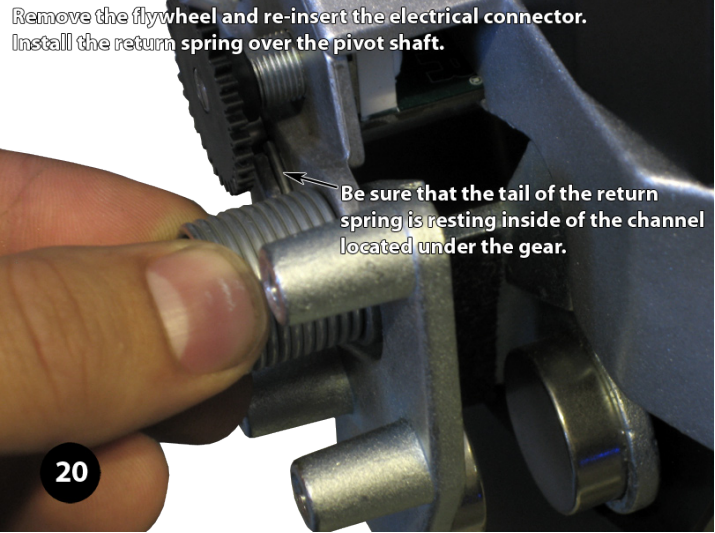

Remove the flywheel and re-insert the electrical connector. Install the return spring over the pivot shaft.

Be sure that the tail of the return spring is resting inside of the channel located under the gear.

20

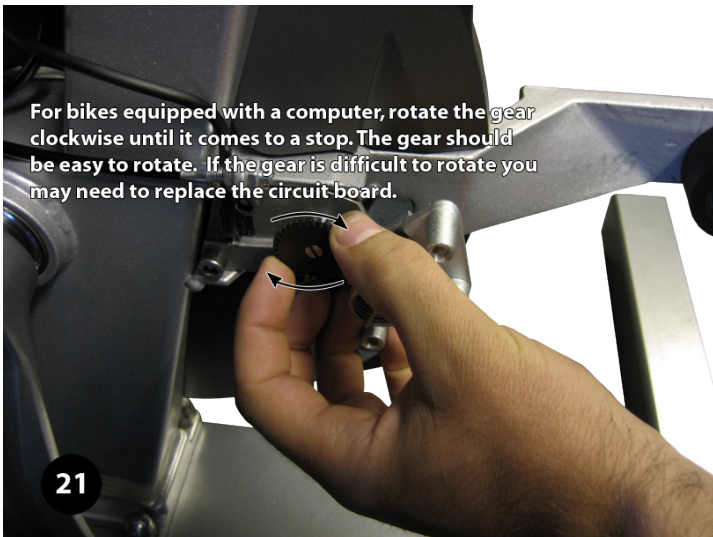

For bikes equipped with a computer, rotate the gear clockwise until it comes to a stop. The gear should be easy to rotate. If the gear is difficult to rotate you may need to replace the circuit-board.

21

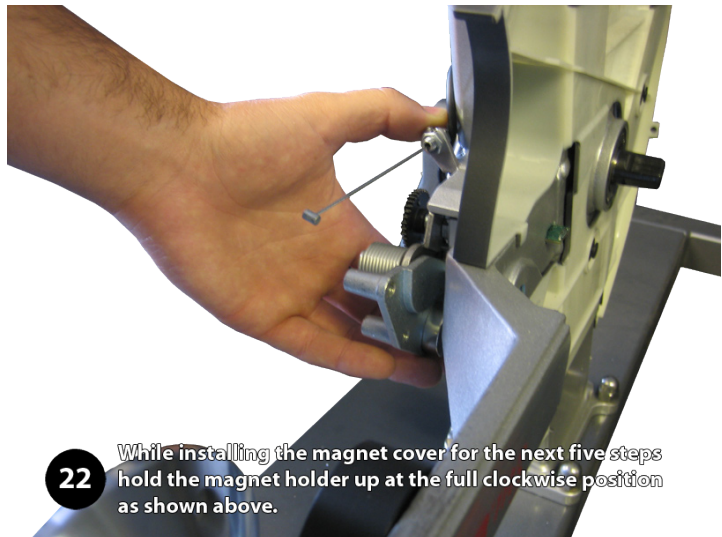

22 While installing the magnet cover for the next five steps hold the magnet holder up at the full clockwise position as shown above.

There are 3 important details to watch when installing the magnet cover: (1) Ensure the spring is loaded correctly, (2) Ensure the gear teeth between the small gear and inside magnet cover mesh properly, and (3) Ensure that the gears are timed correctly with respect to each other. (2 and 3 are for bikes with computer only).

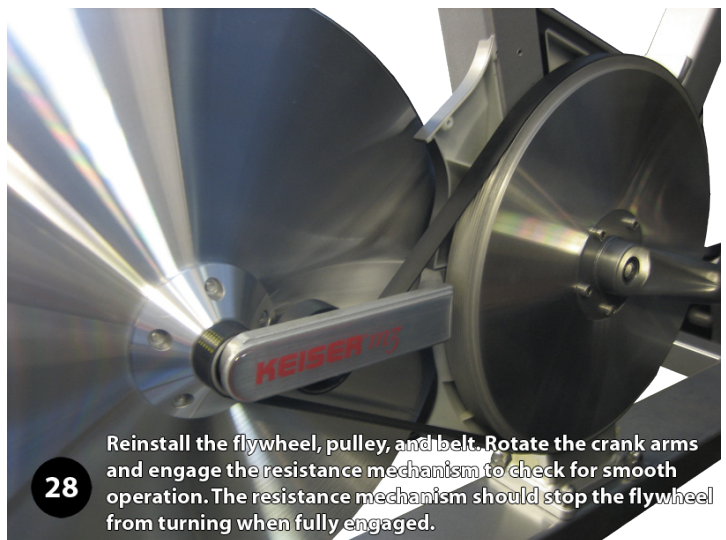
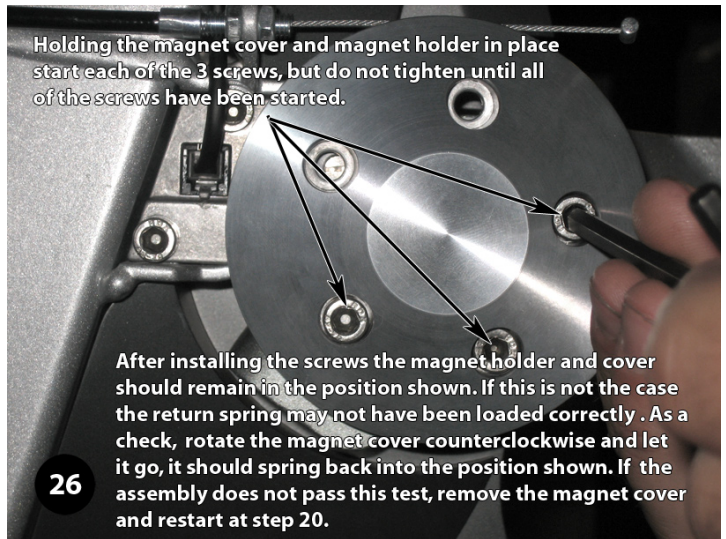
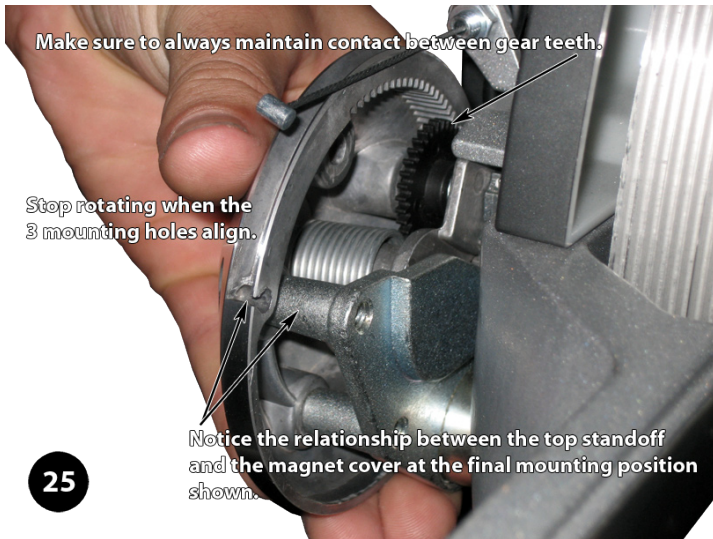
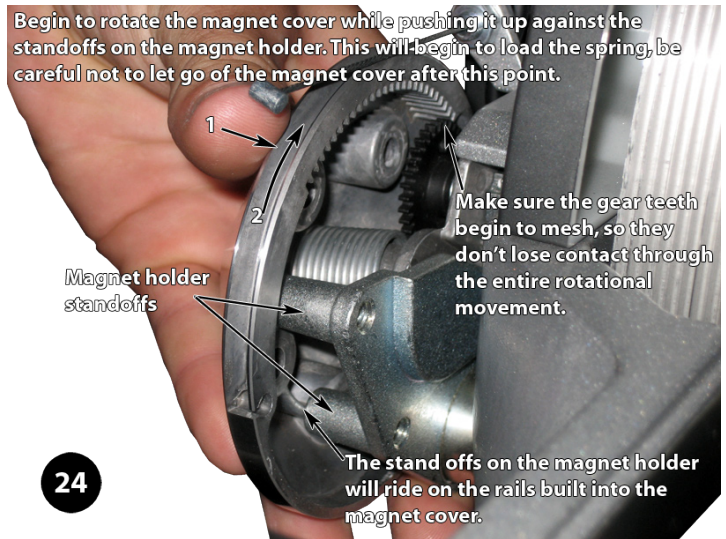
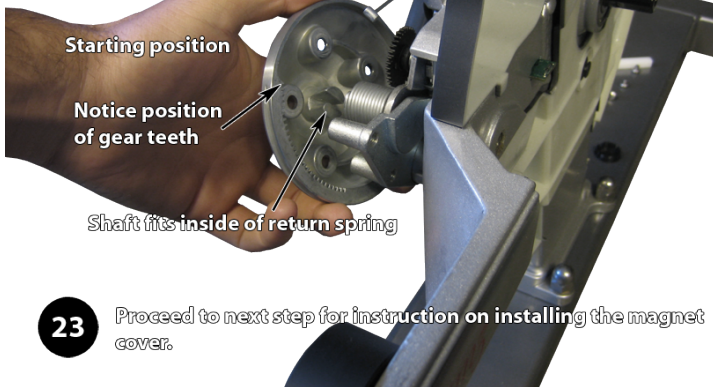

Steps For Belt Removal

Tools Required:
 #1 Phillips screwdriver
 #2 Phillips screwdriver
 Standard screwdriver
 Keiser belt removal kit (PN 550818)

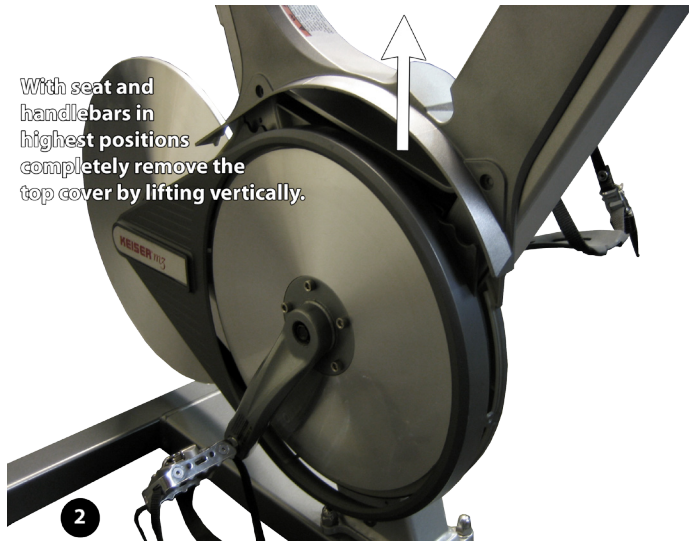
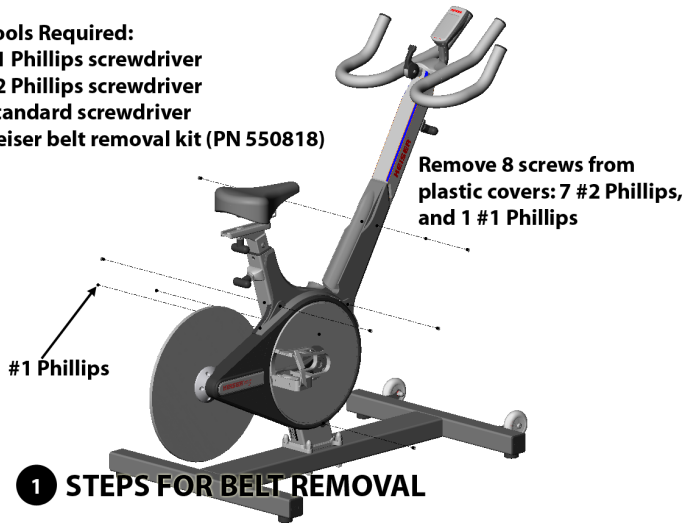

Steps for Belt Installation

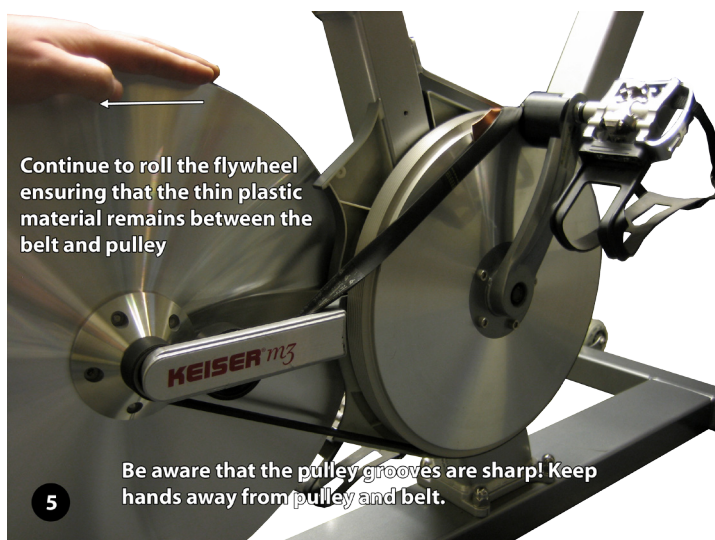
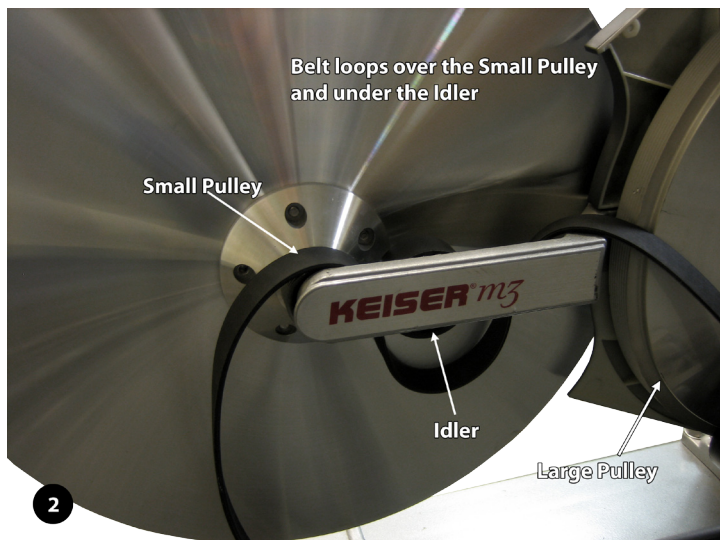

Crank Arm and Axle Removal and Installation

Supplies Required:

- Loctite 242 Thread Locker
- Loctite 680
- Loctite 638
- Alcohol or Acetone

Tools Required:

- 5 mm Hex-Head Wrench
- #1 Phillips Head Screwdriver
- Flat Screwdriver
- Large Hammer
- Torque Wrench
- 14mm Socket
- Crank Arm Puller (KEISER part number 505428)
- Sandpaper (medium grit or coarser)
- Heat gun or hair dryer

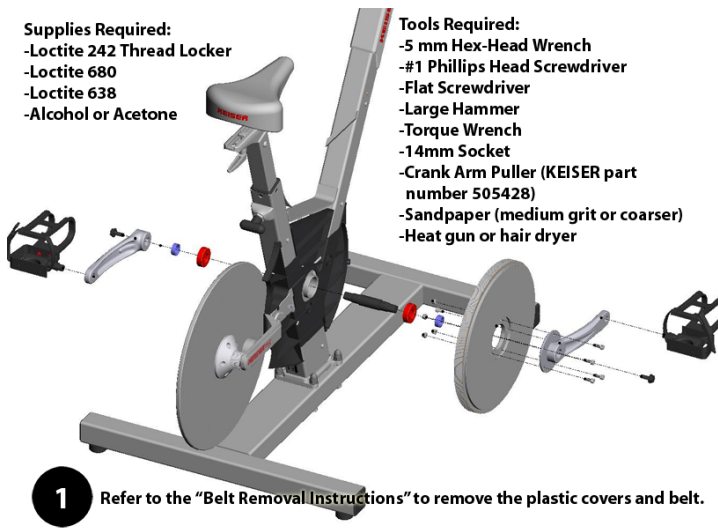

1 Refer to the "Belt Removal Instructions" to remove the plastic covers and belt.



After removing the plastic covers and the belt, remove both left and right crank arm screws using a 14mm socket and ratchet

2

Follow the instructions for the crank arm removal tool (Keiser PN 505428) and remove both left and right crank arms.

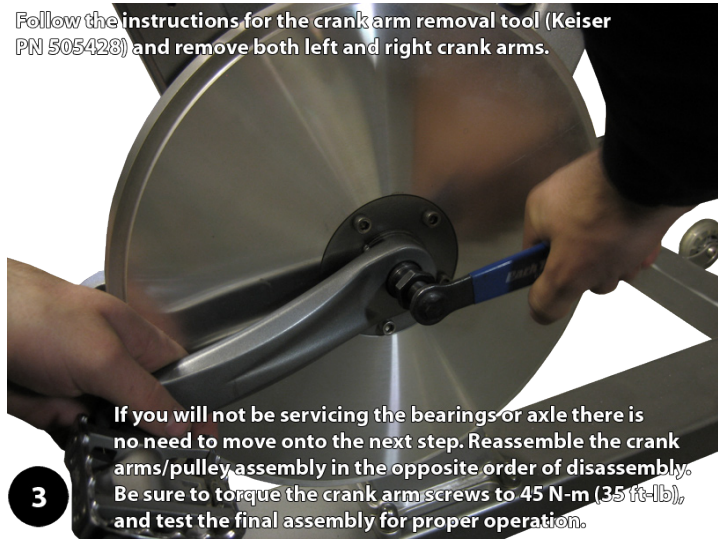

If you will not be servicing the bearings or axle there is no need to move onto the next step. Reassemble the crank arms/pulley assembly in the opposite order of disassembly. Be sure to torque the crank arm screws to 45 N-m (35 ft-lb), and test the final assembly for proper operation.

3



It may be necessary to remove the axle and bearings with a large hammer. If this is the case, take special care not to damage the paint or any other part of the bike. If you miss with the hammer and chip the paint you must repair it with a touch up kit that matches the bike color. Kits are available from the Keiser service department. Be sure to only "tap" the axle on the face as shown, one bearing should come out with the axle. To remove the remaining bearing replace the axle and repeat the procedure from the opposite side.

4



Bearing Housing

For the left and right side of the bearing housing, use sandpaper to remove all of the Loctite residue, and then clean the surfaces with either alcohol or acetone and a clean rag.

Discard

After removing the axle and bearing assembly, discard them and replace with new parts from Keiser. The axle and right side bearing is serviced with a new right side crank arm. See the service assembly drawing for replacement parts.

5



Remove the old crank arm from the pulley. There are four bolts with nuts and one short screw. It may be necessary to tap the crank arm out of the pulley. If this is the case, reinsert the old axle into the crank arm to keep from damaging the pulley. Use the axle and hammer to tap out the crank arm, being careful not to damage the pulley. Once the pulley is removed, clean the mating surface of the pulley with sandpaper and alcohol.

New Crank arm/axle assembly

6

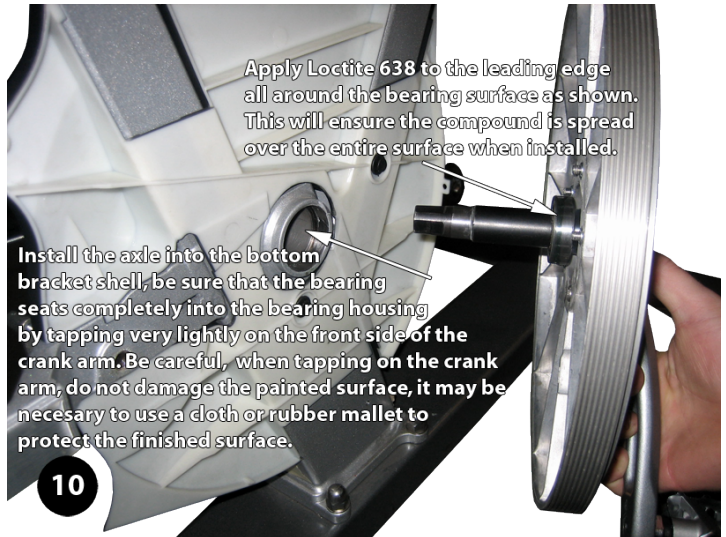
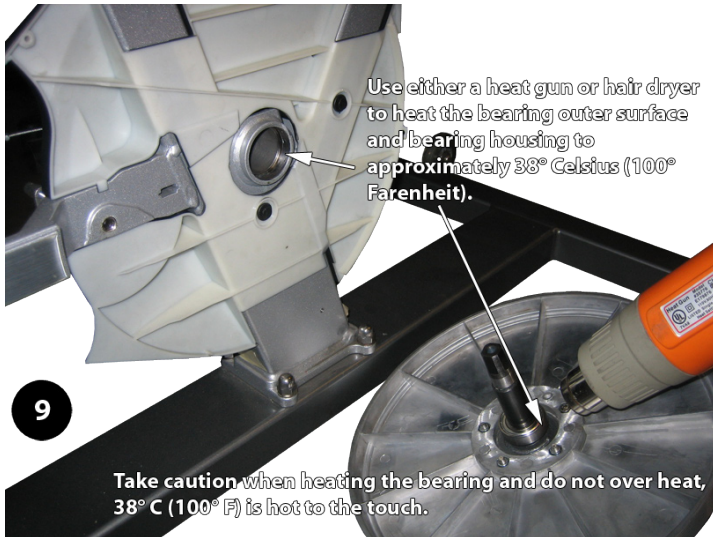
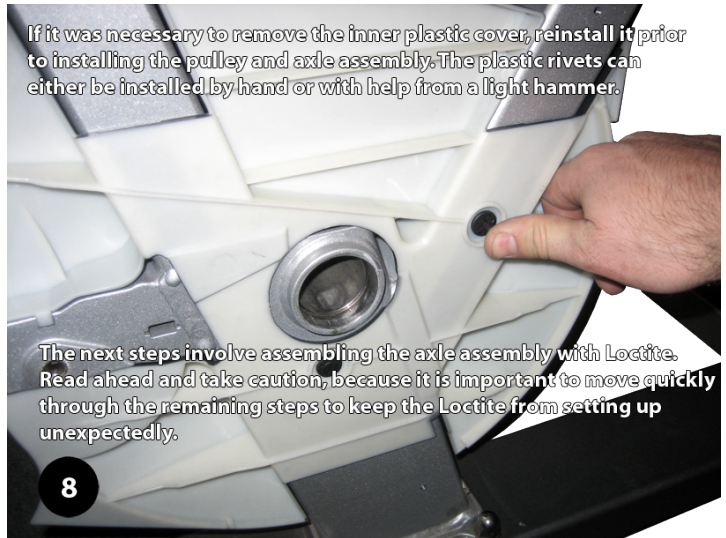

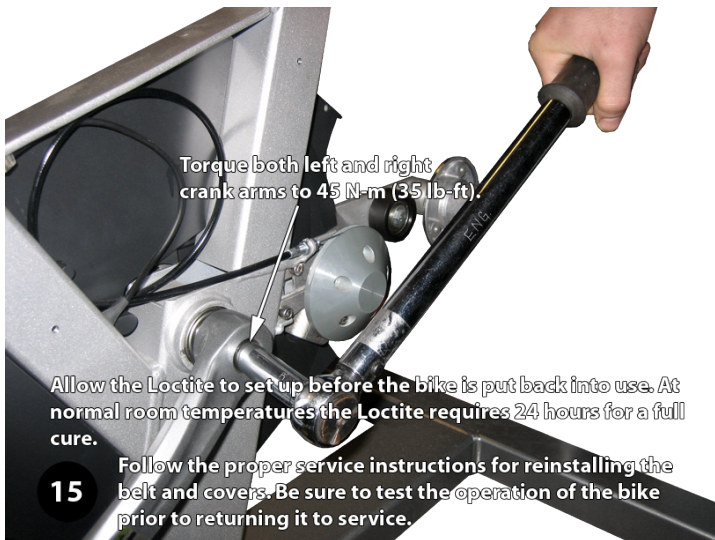
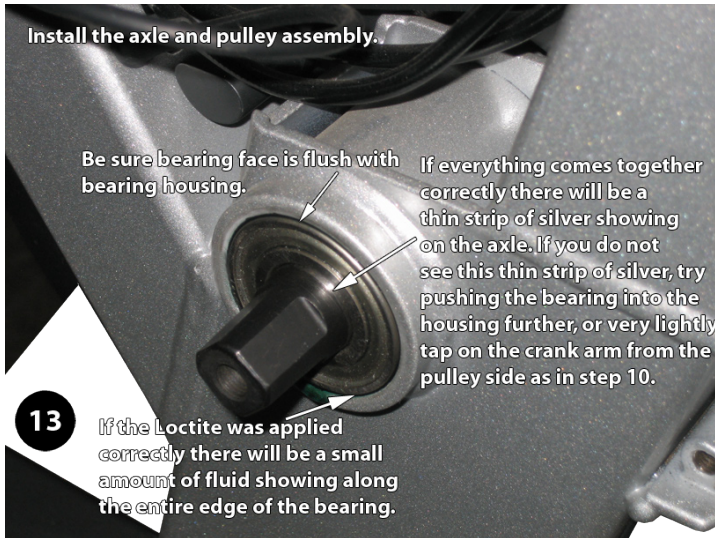

WARNING: Perform the operation below before riding to make sure the bike is fully operational. Failing to test a bike prior to normal use will void your warranty and could result in serious injury.

CHECKING FOR PROPER OPERATION

Pre-Ride Checklist

Please inspect bike carefully and thoroughly before riding.

- All Parts Correctly Installed
- Acorn Nuts Torqued At 45 Nm (35 ft-lbs)
- Pedals Loctited and Torqued To 45 Nm (35 ft-lbs)
- All Screws and Nuts Properly Torqued and Tightened
- Handlebar and Seat Adjustments Operate Properly
- Bike Has Been Polished With Paste or Spray Wax and a Clean Cloth
- Computer Installed and Calibrated and In Working Order (See “Calibrating The Computer”)

Test Ride

Your bike should now be ready to test ride.

1. Adjust the seat and handlebar for proper height and comfort.
2. Secure your feet in the pedals.
3. Move the shifter toward yourself and down and begin pedaling.
4. The computer should wake up and display “ODO” and total distance ridden across the bottom. After approximately 10 secs “ODO” will change to gear and trip.
5. Now move the shifter up and note the gear changing on the computer and the resistance getting harder.
6. Ride at various speeds and resistances to check for noise and vibration.
7. Move the shifter to full forward position to check that the emergency brake stops the flywheel from turning.
8. You have completed the test.
9. Enjoy your ride.

NOTE: Since we are always striving to improve our products; our products are subject to change without notice.

NOTICE

Users, agents or anyone directing the use of this equipment shall determine the suitability of the product for its intended use, and said parties are specifically put on notice that they shall assume all risk and liability in connection herewith.

Preventative Maintenance Chart

Every Class	Member thoroughly inspect each cycle (1)
	Member wipe off sweat (2)
Weekly for the 1st Month	Check and re-torque crank arms and pedals (3)
Weekly	Thoroughly inspect each cycle (4)
	Clean with warm water and soft towel (5)
	Check computer for low battery indication (6)
Monthly	Check and re-torque crank arms, pedals, and main frame nuts (3)
	Wax those areas most in contact with sweat (7)
	Lubricate T-Handle threads used on adjustments (8)

1. Each member should thoroughly inspect each cycle to make sure it is in safe and proper working order.
2. Each member should wipe off their own sweat after each class with a soft towel (their towel) or cloth.
3. Check and retorque the screw holding the crank arm to the axle and the pedals. The torque for both is 35 ft-lbs (47Nm)
4. Thoroughly inspect each cycle to make sure it is in safe and proper working order. Pay particular attention to loose screws, nuts & bolts, crank arms, pedals, pedal cages, handlebar, saddle, T-Handle adjustments, worn pedal straps, etc.
5. Clean with warm water and a soft cloth the parts of the cycle that are dirty or come in contact with sweat. Do not use household or industrial cleaners, because many of them are designed to clean, glass, tile, porcelain, and greasy or oily surfaces and can destroy the protective finish of the paint. If you need to use soap, use a mild dish washing soap followed by an automotive treatment such as Meguiar's Quick Detailer Mist and Wipe.
6. Check batteries. IF YOU HAVE MULTIPLE BIKES, WE SUGGEST ALL COMPUTER BATTERIES BE CHANGED AT THE SAME TIME (2 AA batteries per bike). See "Computer Battery Replacement" section for instruction.
7. It is not necessary to wax the entire bike monthly, but it is very important to wax those areas that come in contact with sweat, which are the most vulnerable to rust. Use an easily applied automotive treatment such as Meguiar's Quick Detailer Mist and Wipe. Please note that failure to apply a coat of wax to high sweat areas at least once a month will decrease paint and frame life due to corrosion and will void the warranty.
8. Remove, clean, and lubricate the threads on the T-Handle adjustments. Since both the threaded stud and the threaded nut are stainless steel it is very important to keep the threads lubricated with a heavy grease, preferably white or clear in color, such as Hydrotex MT-55 or Dow Corning 111.

Keiser M3 Indoor Cycle Warranty Terms

The Keiser M3 Indoor Cycle is warranted to the original purchaser, to be free from defects in materials and workmanship.

Not Covered Under Warranty

- Loss caused by accident, abuse, improper use or neglect.
- Improper maintenance.
- Improper assembly by the purchaser.
- Failure to follow instructions as stated in any of the manuals provided with the

Keiser M3 Indoor Cycle.

The warranty terms begin with the date of original delivery to be evidenced by appropriate shipping documents. Any alteration of the equipment so listed without express written consent of Keiser shall constitute a waiver by the buyer of this warranty. This warranty does not cover other brand name products distributed, but not manufactured by Keiser, which are subject to their respective manufacturers warranties. During the warranty period, warranted defects will be repaired at Keiser, Fresno California, or the defective part will be replaced, at the option of the manufacturer, without charge for either parts or labor to repair the defective part.

This warranty does not cover the removal of the defective part and installation of the repaired part. All claims under the warranty must be in writing and authorization obtained from the manufacturer, Keiser, to return the defective parts for exchange. Defective parts must be returned to Keiser. The customer is responsible for all transportation costs on returned items to and from the point of manufacture.

Users, agents, or anyone directing the use of said equipment shall determine the suitability of the product for its intended use, and said parties are specifically put on notice that they shall assume all risk and liability in connection herewith. The foregoing warranties are in lieu of and exclude all other warranties not expressly set forth herein, whether expressed or implied by operation of law or otherwise, including but not limited to any implied warranties of merchantability or fitness.

Keiser shall in no event be liable for incidental or consequential losses, damages or expenses in connection with exercise products. Keiser's liability hereunder is expressly limited to the replacement of parts not complying with this warranty or, at Keiser's election, to the repayment of an amount equal to the purchase price of the parts in question. Keiser is not responsible for labor charges incurred in the replacement of defective parts. Keiser may, at its discretion, require the return of all defective parts. The customer is responsible for all transportation costs on warranted items to and from the point of manufacture. Replacement products are warranted for the balance of the original warranty period.

All Keiser equipment sold by Keiser distributors, dealers, or salespeople must be registered for warranty purposes. The warranty registration form must be filed within 7 days of the sale or installation. Keiser equipment exported out of the US or Canada will be void of warranty unless purchased directly through a Keiser international distributor or dealer in the country of installation, or direct from Keiser's international division.

Keiser M3 Shift Cable replacement

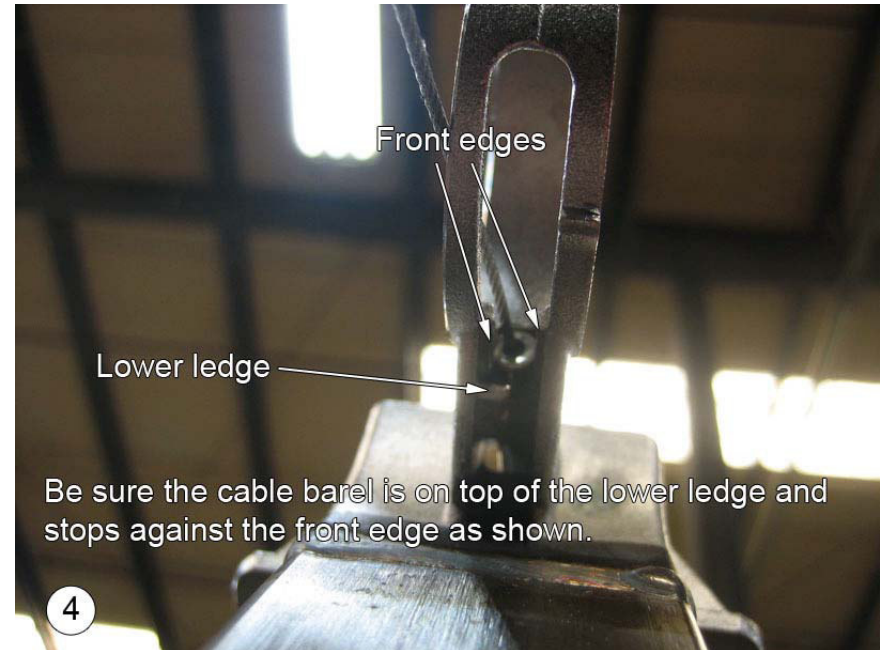

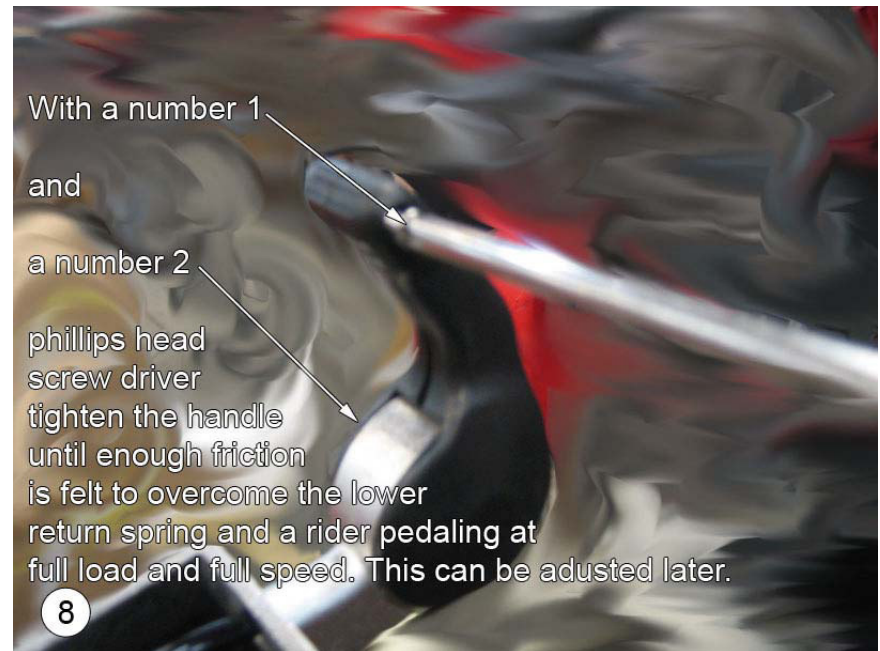
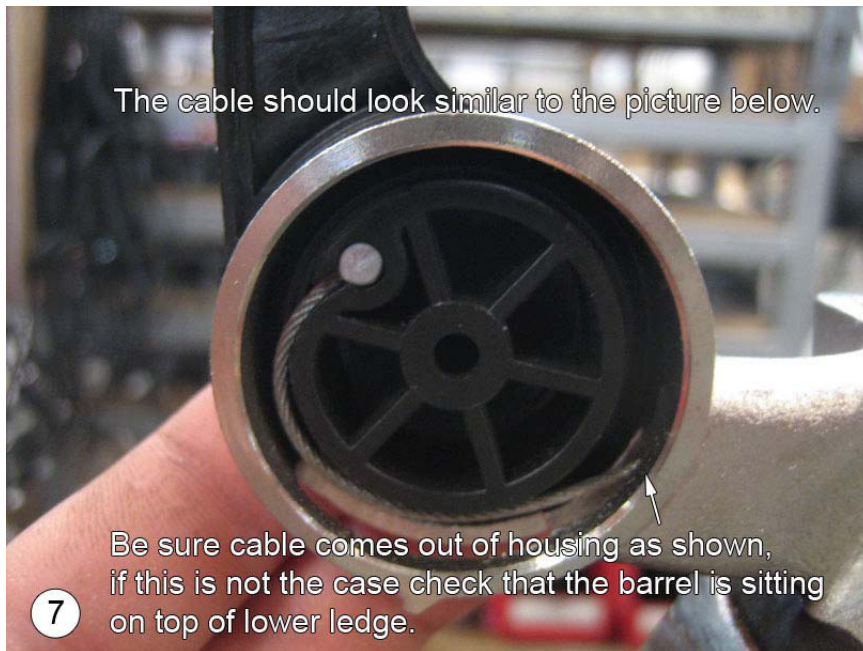





Questions? Please Contact the Keiser Service department

KEISER[®]

2470 S. Cherry Ave Fresno CA. 93706

Toll Free: 1.800.888.7009 Phone: 559.256.8000

Fax: 559.256.8100 www.keiser.com

M3 and M5 Retrofit Leveler Installation

Parts and Tools Required

1. Leveler Kit, which includes

- 3 replacement glides and bolts
- 1 leveler glide
- 1 threaded insert

2. 3/16 Hex wrench

3. Power Drill with 11mm step bit

***Note – The step bit must have an 11 mm step and each step must be at least 3.5 mm deep.**

4. Crimping Tool, Provided by Keiser

STEP 1.

Lower the handlebar to the lowest position and re-secure the handle

STEP 2.

Tilt the M3 or M5 onto its transport wheels and lower it down, resting it on the handlebar.

STEP 3.

Remove the four existing glides with 3/16 hex. Discard old glides and hardware.

STEP 4.

Install 3 new glides and bolts in existing holes in the front, and rear right of the frame.

STEP 5.

Expand the remaining tap hole to 11mm using the step drill bit and power drill.

STEP 6.

Loosen the band on the crimping tool, and fully open the handles.

STEP 7.

Hand tighten the supplied threaded insert onto the mandrel of the crimping tool until it bottoms out.

STEP 8.

Place the threaded insert into the 11mm hole. Be sure the insert is square to the frame surface.

STEP 9.

With a partner stabilizing the machine, crimp the insert by fully closing, then fully opening the handles. This will require a substantial amount of force.

STEP 10.

Pull the screw rod slowly to back out the screw mandrel from the threaded insert, then push screw rod back in completely to get ready for the next use.

STEP 11.

Screw in the provided leveler glide completely.

STEP 12.

Tilt the machine on to its right side, exposing the leveler glide. Adjust and re-check until it sits level with the surface.

KEISER[®] m3

Flywheel Guard Installation

Equipment You Will Need

6mm Allen Wrench	Two 10mm Wrenches
------------------	-------------------

Step 1: Make sure to have all parts and tools present prior to assembly.

PARTS INVENTORY

- A) Bolt and Nut
- B) Brackets
- C) Tube

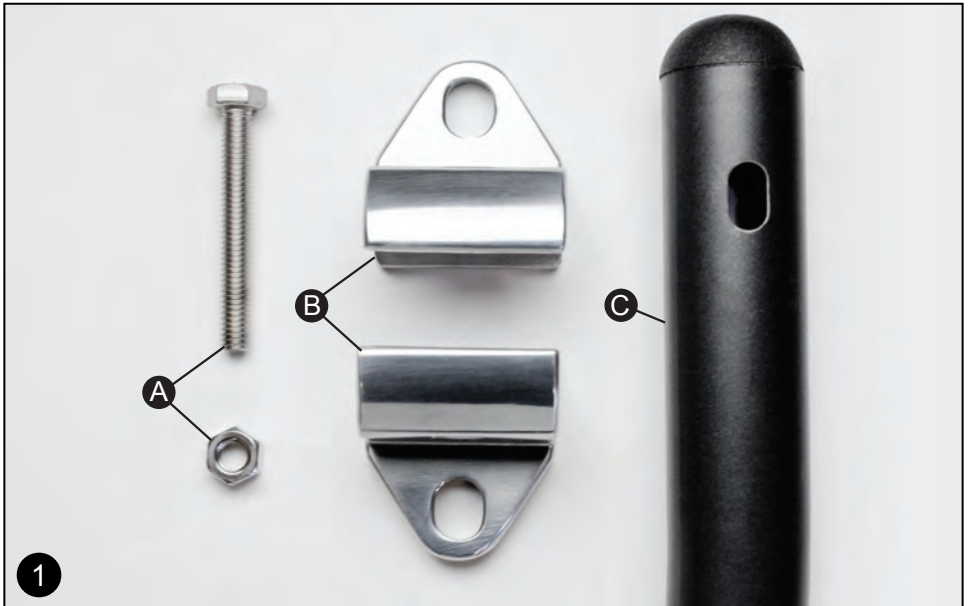

Step 2: Assemble the brackets (B) to the tube (C) With the bolt and nut (A) finger tight.

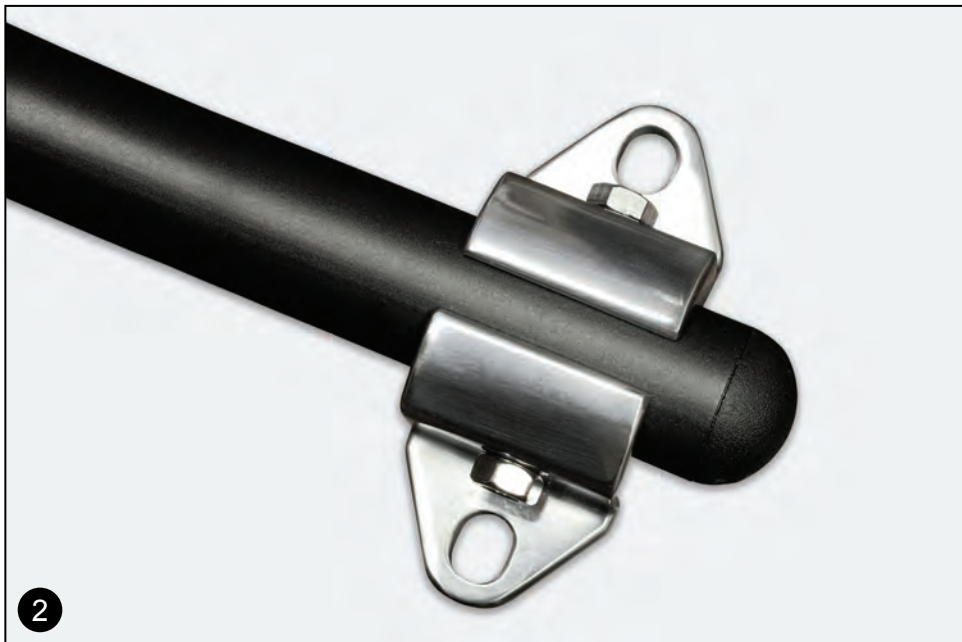

Step 3: Make sure the flywheel is centered in the middle of the 2x4 tube of the base frame. Remove the two screws and washers from the base frame. These Screws will be used to mount the flywheel guard in step 4.

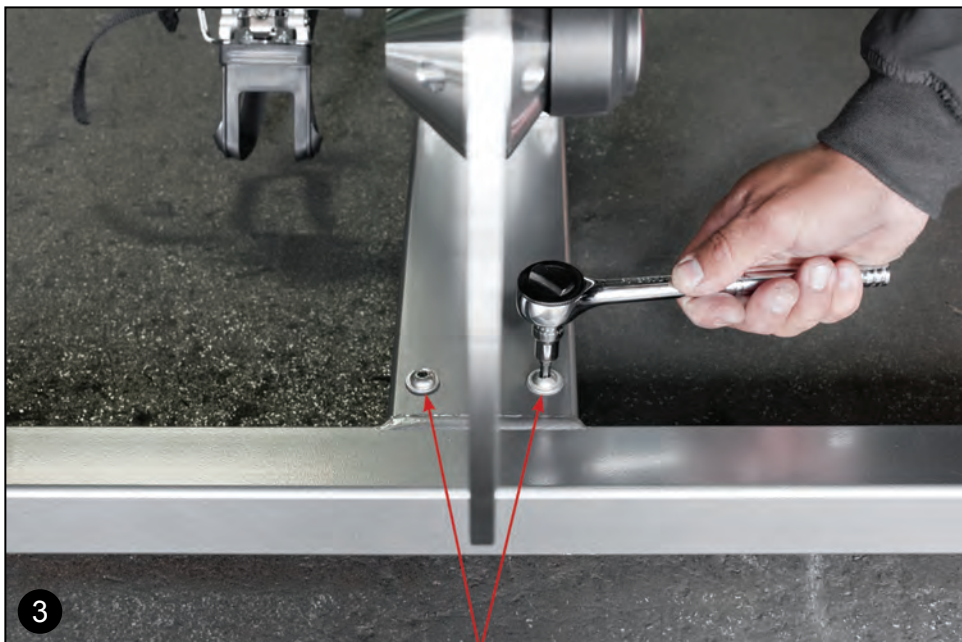

Step 4: Place the assembled flywheel guard over the holes and tighten brackets to the base frame with the screws and washers that were removed in step three (inset). Do not fully tighten the bolts.



Step 5: Make sure the Tube is centered over the Flywheel. The Flywheel must be completely hidden behind the Tube as shown.

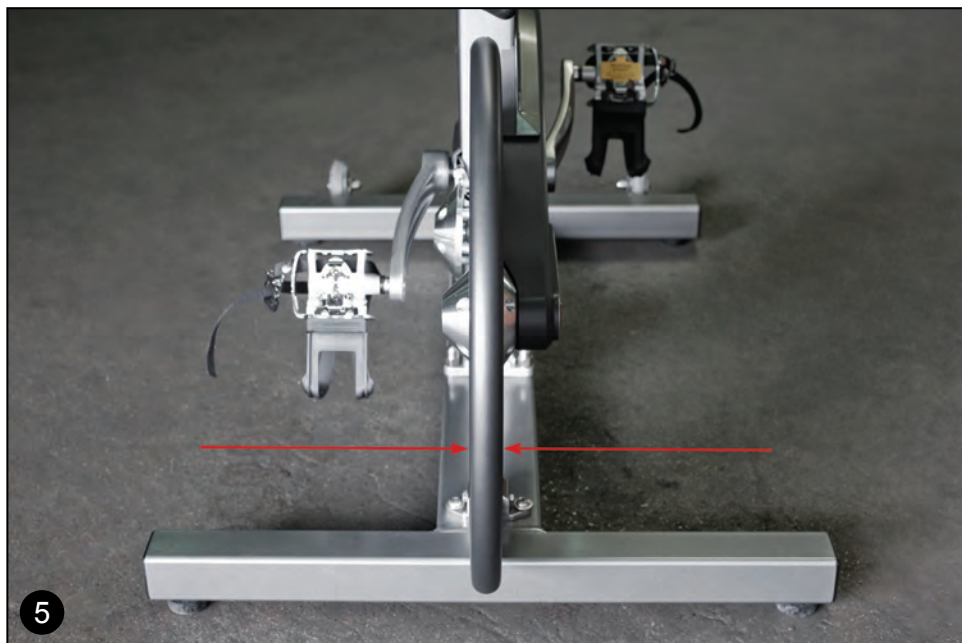

Step 6: By not fully tightening the bolts, the brackets allow the tube to move front to back, and left to right to some degree. Center the tube with as much clearance as possible from the flywheel, then fully tighten all the bolts.



If you experience any problems please contact our Service Department
USA 1 (800) 888-7009 | International +1 (559) 256-8000 | service@keiser.com

KEISER[®]
THE POWER IN HUMAN PERFORMANCE
(800) 888-7009 keiser.com

KEISER[®]

SERVICE BULLETIN

Keiser is committed to building the best products possible for our customers.

It has come to our attention, that when seat posts on the M3 Indoor Cycle are not properly tightened, the seat post may become loose while riding. If you have experienced this at your facility, please contact our Service Department for further instructions.



KEISER SERVICE IS AVAILABLE MONDAY-FRIDAY 7:00 A.M. - 5:00 P.M. PST.

P: 559.256.8000 | TF: 1.800.888.7009 | F: 559.256.8100 | E: service@keiser.com